



Aftermarket Product Catalog

Rev. 10/2022

AFTERMARKET PRODUCTS

UPGRADES

SERVICE

PARTS





For more information on any product or service you find in this catalog, please feel free to contact us:

[WLS Service Mailbox](#)

856-273-3377

<https://www.weilerls.com>

Table of Contents

Click any item to navigate to that section/page

Introduction

Training Courses

RL-420 Rotary Labeler

VR-72 Trunnion Labeler

Service Agreements

Annual Service Agreement Plans

Parts & Kits

Full Annual Rebuild Kit for Trapped Cam Lower

Full Annual Rebuild Kit for Open Cam Lower

Full Annual Rebuild Kit for Upper Cam

Full Annual Rebuild Kit for Push Pull Legacy 4" & 6"

Rotary Adapter Bearing Replacement Assembly

Upgrades & Retrofits

Performance Level D ISO 13849-1 Compliant Retro Guarding Package

SLC to CompactLogix Conversion

Obsolescence Evaluation



For more information on any product or service you find in this catalog, please feel free to contact us:

[WLS Service Mailbox](#)

856-273-3377

<https://www.weilerls.com>

Introduction

For over 30 years WLS has designed, manufactured, integrated, and supported some of the most sophisticated and advanced rotary and in-line pressure sensitive labeling equipment and solutions in the marketplace.

WLS has active machine installations worldwide and offers an industry-leading two-year warranty on all new equipment. With one of the most extensive North American field support networks in the industry, and with the addition of European-based sales and service, WLS is well placed to deliver world-class support to all our customers regardless of geographical location.

At WLS, we pride ourselves on having aftermarket service that is among the best – if not *the* best – in the industry. When you select WLS as a partner, you will have the peace of mind that comes from knowing that we will take care of you, whether your need is emergency service, preventive maintenance, spare parts, upgrades, or retrofits, in addition to site installations and training. ***Customer satisfaction is our focus!***

Because of our unwavering service-driven culture, our customers have repeatedly indicated their overall satisfaction with WLS quality and services.

All our US based field service technicians are centrally located at our head office in Moorestown, NJ. Each one of our technicians spends about 50% of their time working on the shop floor. Having the close connection to the manufacturing facility gives our technicians the ability to stay up to date with all our equipment and have an explicit understanding of manufacturing, installation, and maintenance of each machine that leaves our facility. This provides our customers with consistent, high quality and experience for remote and onsite support throughout the life of their machine.

This catalog features some of our most popular aftermarket products and services. Please feel free to contact us using the contact information to the left for any of your aftermarket needs. We look forward to partnering with you to ensure your equipment has a long and efficient service life.



TRAINING COURSES

At WLS, we understand that the successful operation of any equipment is based on a sound understanding of all the functions and operations by operators, supervisors, and maintenance staff. With this in mind, we have developed extensive training courses which cover both theoretical and practical training on our equipment.

Training is a mix of classroom and hands on learning with all training material based exclusively on the machine that is being considered. Each trainee will receive a course handbook with a detailed explanation of all the relevant equipment components, their correct operation, and adjustments, as well as instruction in setup, location and repair of common faults that occur in general machine operation.

Each course can be tailored to precisely meet our customers' requirements to ensure that all the desired training is completed satisfactorily to meet the needs and training needs of all individuals. The course is led by a combination of professional WLS-approved trainers and WLS Field Service Technicians to ensure that the course is both successful and relevant, resulting in knowledgeable, motivated, and competent operators and maintenance personnel.

Please contact our WLS Service team to discuss how you can take advantage of this opportunity to take your operators and the success of your WLS equipment to the next level.

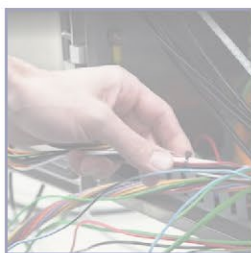



Course Length:

Customizable to individual requirements

Recommended For:

Operators, Process Technicians, Supervisors, Maintenance Technicians

Prerequisites:

None

Delivery Method:

- ✓ Lecture
- ✓ Instructor-led discussion
- ✓ Hands-on, with actual

Course Description

This course provides information on the makeup, operation, and maintenance of the RL-420 Rotary Labeler. The instruction will cover the purpose, function, and operation of labeler components, as well as the sequence of operation, changeover, preventive maintenance, and troubleshooting. Documentation for the course is tailored for each machine configuration including any options. The course includes a mix of classroom time led by a qualified instructor as well as time on the floor for hands-on learning on the actual machine, allowing personnel to put the learned information into practical use.



Course Purpose

Upon completion of this course, the participant should be able to:

- Describe the purpose and function of components of the labeler
- Locate components within the labeler
- Describe how product moves through the labeler and how the machine components affect movement
- Describe parameters that require setting prior to production, and how incorrect settings affect operation
- Locate and repair faults within the labeler

This course is designed to be conducted during commissioning, allowing personnel to learn about and operate the labeler before going to live production, allowing a vertical startup. The course provides approximately 4 hours of classroom time and 4 hours of hands-on time for operators, supervisors, and mechanics, and approximately 6 hours of classroom time and 4 hours of hands-on time for electricians. Additional time includes discussion of the controls system, I/O points, and schematics. All courses discuss HMI screens applicable to various access levels. Course length depends on machine configuration and installed options. Multiple sessions can be conducted across all shifts to capture all affected personnel.



Course Length:

Customizable to individual requirements

Recommended For:

Operators, Process Technicians, Supervisors, Maintenance Technicians

Prerequisites:

None

Delivery Method:

- ✓ Lecture
- ✓ Instructor-led discussion
- ✓ Hands-on, with actual

Course Description

This course provides information on the makeup, operation, and maintenance of the VR-72 Trunnion Labeler. The instruction will cover the purpose, function, and operation of labeler components, as well as the sequence of operation, changeover, preventive

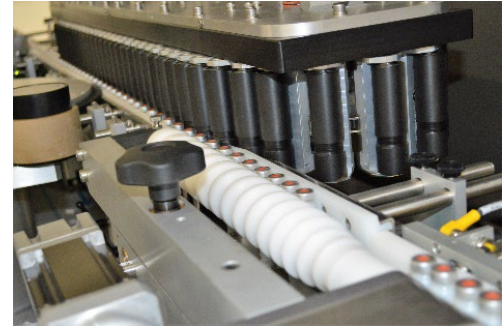

maintenance, and troubleshooting. Documentation for the course is tailored for each machine configuration including any options. The course includes a mix of classroom time led by a qualified instructor as well as time on the floor for hands-on learning on the actual machine, allowing personnel to put the learned information into practical use.

Course Purpose

Upon completion of this course, the participant should be able to:

- Describe the purpose and function of components of the labeler
- Locate components within the labeler
- Describe how product moves through the labeler and how the machine components effect movement
- Describe parameters that require setting prior to production, and how incorrect settings affect operation
- Locate and repair faults within the labeler

This course is normally conducted during commissioning, allowing personnel to learn about and operate the labeler before going to live production, allowing a vertical startup. The course provides approximately 4 hours of classroom time and 4 hours of hands-on time for operators, supervisors, and mechanics, and approximately 6 hours of classroom time and 4 hours of hands-on time for electricians. The additional time includes discussion of the controls system, I/O points, and schematics. All courses discuss HMI screens applicable to various access levels. Course length depends on machine configuration and installed options. Multiple sessions are conducted across all shifts to capture all affected personnel.





SERVICE AGREEMENTS

Maximizing machine availability and prevention of unforeseen downtime is key to optimizing output and profitability. WLS offers a tiered Annual Service Agreement to help our customers plan their PM costs for the year and ensure that they have access to our highly trained personnel when required.

Our Service Agreements are fully customizable to meet the varied needs of our customers and can be tailored to your exact requirements. All our contracts include two PM / training visits and one emergency visit. Use the planned visits to carry out routine checks on all the wear items on the equipment, ensure maximum efficiency or give your operators some refresher training and maintenance assistance. The inclusion of the emergency visit gives the peace of mind that if the machine does have an unplanned event that requires our assistance, your call will be prioritized, and you will receive expedited support.

We are committed to ensuring that our customers receive world class service that enhances the already outstanding equipment that we offer. Contact the WLS Service Team to discuss your requirements and learn more about how we can work together to meet your goals.





ANNUAL SERVICE AGREEMENTS

Choose the plan that's right for you

Unwavering passion for service...

SILVER

FEATURES

- One specially trained WLS Service Technician on-site for up to 8 hours per day with a daily schedule to be determined by site management
- Shift differentials
- Machine safety inspection
- Preventative maintenance inspection and tasks
- Verification of home reference positions
- Basic adjustments and repairs
- Technician may perform miscellaneous tasks as needed and/ or requested, including refresher training
- Comprehensive Machine Evaluation Report
- Travel time and on-site labor included
- Local accommodations and meals included
- Ground transportation included
- Customized plans available

BENEFITS

- On-line troubleshooting
- Phone support
- 24-hour turnaround on emergency parts
- Higher machine availability through reduced downtime
- Reduced service costs
- Early detection of part wear & failures
- Reduced spare parts cost
- Fixed cost for preventative maintenance

INCLUDED

- 2 SEMI-YEARLY PM VISITS
- 1 EMERGENCY VISIT

GOLD

FEATURES

- One specially trained WLS Service Technician on-site for up to 8 hours per day with a daily schedule to be determined by site management
- Shift differentials
- Machine safety inspection
- Preventative maintenance inspection and tasks
- Verification of home reference positions
- Basic adjustments and repairs
- Technician may perform miscellaneous tasks as needed and/ or requested, including refresher training
- Comprehensive Machine Evaluation Report
- Travel time and on-site labor included
- Local accommodations and meals included
- Ground transportation included
- Customized plans available

BENEFITS

- On-line troubleshooting
- Phone support
- 24-hour turnaround on emergency parts
- Higher machine availability through reduced downtime
- Reduced service costs
- Early detection of part wear & failures
- Reduced spare parts cost
- Fixed cost for preventative maintenance

INCLUDED

- 2 SEMI-YEARLY PM VISITS
- 1 EMERGENCY VISIT
- 10% PARTS DISCOUNT
- 10% SERVICE RATED DISCOUNT

PLATINUM

FEATURES

- One specially trained WLS Service Technician on-site for up to 8 hours per day with a daily schedule to be determined by site management
- Shift differentials
- Machine safety inspection
- Preventative maintenance inspection and tasks
- Verification of home reference positions
- Basic adjustments and repairs
- Technician may perform miscellaneous tasks as needed and/ or requested, including refresher training
- Comprehensive Machine Evaluation Report
- Travel time and on-site labor included
- Local accommodations and meals included
- Ground transportation included
- Customized plans available

BENEFITS

- On-line troubleshooting
- Phone support
- 24-hour turnaround on emergency parts
- Higher machine availability through reduced downtime
- Reduced service costs
- Early detection of part wear & failures
- Reduced spare parts cost
- Fixed cost for preventative maintenance
- Faster on-site emergency support

INCLUDED

- 2 SEMI-YEARLY PM VISITS
- 1 EMERGENCY VISIT
- 10% PARTS DISCOUNT
- 10% SERVICE RATED DISCOUNT
- 24/7 EMERGENCY PHONE SUPPORT
- 1 YEAR EXTENDED WARRANTY



PARTS & KITS

Our WLS Parts Team is always ready to assist our customers with all their equipment parts requirements. Please contact us either by phone or email with your requirements and we will ensure you receive the high-quality support you expect from us.

While we sell individual parts for all our equipment, we recognize the practicalities of changing out multiple parts at the same time. On many occasions, multiple wear parts may be due for replacement around the same time, or it may be more efficient to replace numerous related parts at one time due to the invasive work that is required to change some components.

To help keep our customers equipment running at maximum efficiency and preserve production uptime, WLS provides several refurbishment and PM kits that will take care of a section of parts in one planned maintenance event. Please contact us with your machine details and we can recommend the specific package you require.

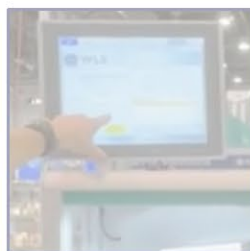



For more information on any product or service you find in this catalog, please feel free to contact us:

[WLS Service Mailbox](#)

856-273-3377

<https://www.weilerls.com>

Description

If your product is slipping during application, it may be a sign of worn parts or bearings seizing.

This kit provides all the required parts to replace potential wear parts in one planned operation. Save money by purchasing the kit instead of individual parts.

We recommend changing these as part of planned annual maintenance.

Installation can be provided through our service department.

Parts supplied in the kit are identified in the schematic below:

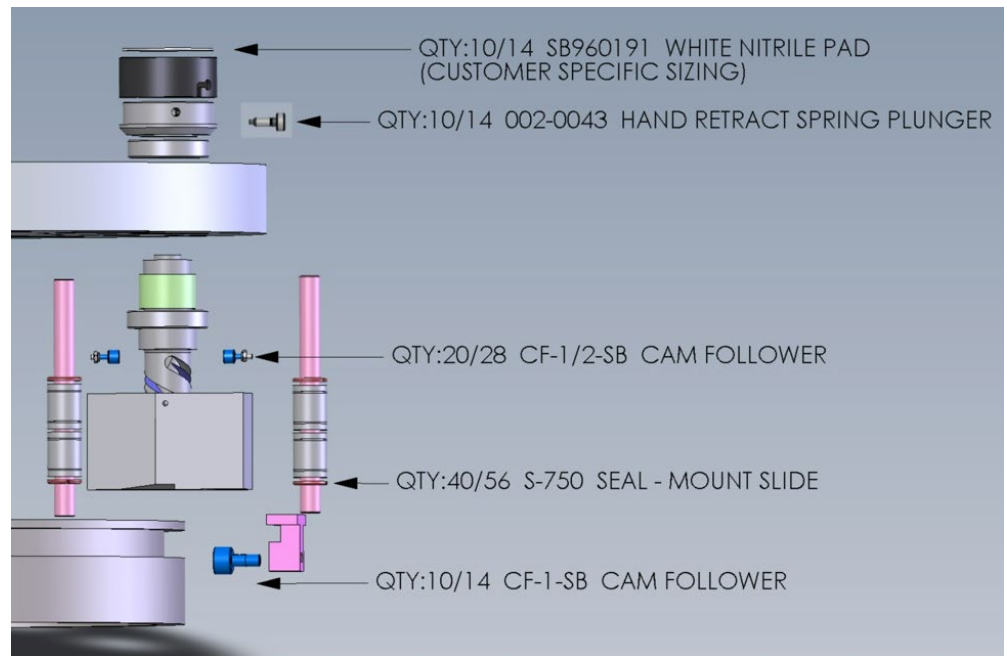

* This kit is available for 10 and 14 station labelers *

Part Numbers

10 Station Labeler WLS Part #: KIT101

14 Station Labeler WLS Part #: KIT101-14



For more information on any product or service you find in this catalog, please feel free to contact us:

[WLS Service Mailbox](mailto:WLS@weilrls.com)

856-273-3377

<https://www.weilrls.com>

Description

If your product is slipping during application, it may be a sign of worn parts or bearings seizing.

This kit provides all the required parts to replace potential wear parts in one planned operation. Save money by purchasing the kit instead of individual parts.

We recommend changing these as part of planned annual maintenance.

Installation can be provided through our service department.

Parts supplied in the kit are identified in the schematic below:

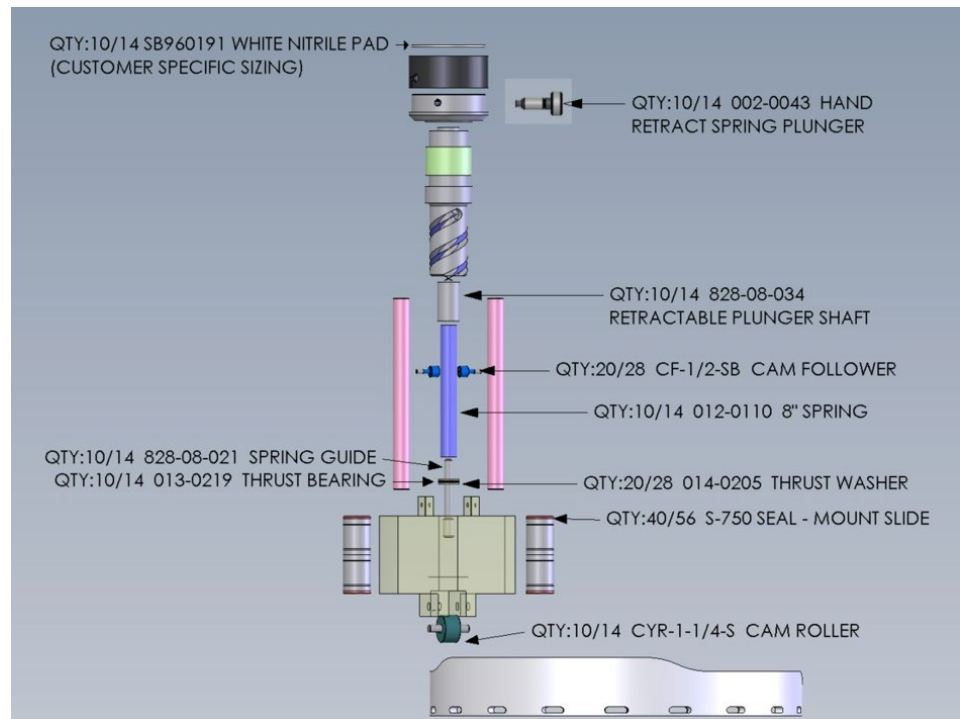

*** This kit is available for 10 and 14 station labelers ***

Part Numbers

10 Station Labeler WLS Part #: KIT102

14 Station Labeler WLS Part #: KIT102-14



For more information on any product or service you find in this catalog, please feel free to contact us:

[WLS Service Mailbox](mailto:WLS_Service_Mailbox@weilerls.com)

856-273-3377

<https://www.weilerls.com>

Description

If you are experiencing air leaks or rotation noise, it may be time to change your seals bearings on the Upper Cam.

This is a full annual rotary rebuild kit for top tooling. Includes new bearings, pads and grease for a complete rebuild. Installation tool is included. Save money by purchasing the kit instead of individual parts.

We recommend changing these as part of planned annual maintenance.

Installation can be provided through our service department.

Parts supplied in the kit are identified in the schematic below:

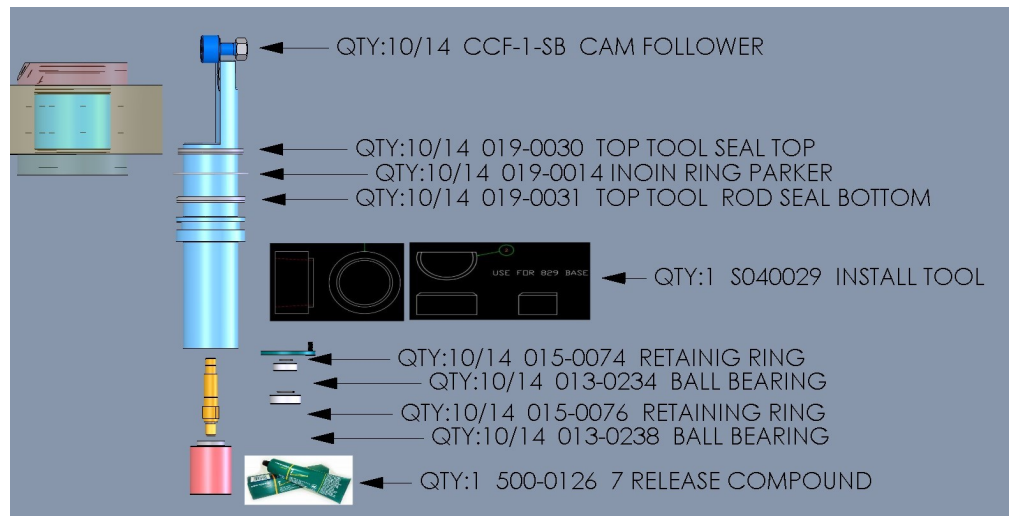

*** This kit is available for 10 and 14 station labelers ***

Part Numbers

10 Station Labeler WLS Part #: KIT103

14 Station Labeler WLS Part #: KIT103-14



For more information on any product or service you find in this catalog, please feel free to contact us:

[WLS Service Mailbox](mailto:WLS_Service_Mailbox@weilerls.com)

856-273-3377

<https://www.weilerls.com>

Description

If you are experiencing label application issues, loose web, web breaks, print variation, vision filed alignment, it may be a sign of worn parts in the push pull assembly.

This kit provides all the required parts to replace potential wear parts for 4" and 6" Push Pull label heads in both STD and X2 formats. Purchasing this kit allows complete rebuild in one planned operation. Save money by purchasing the kit instead of individual parts.

We recommend changing these as part of planned annual maintenance.

Installation can be provided through our service department.

Parts supplied in the kit are identified in the schematic below:

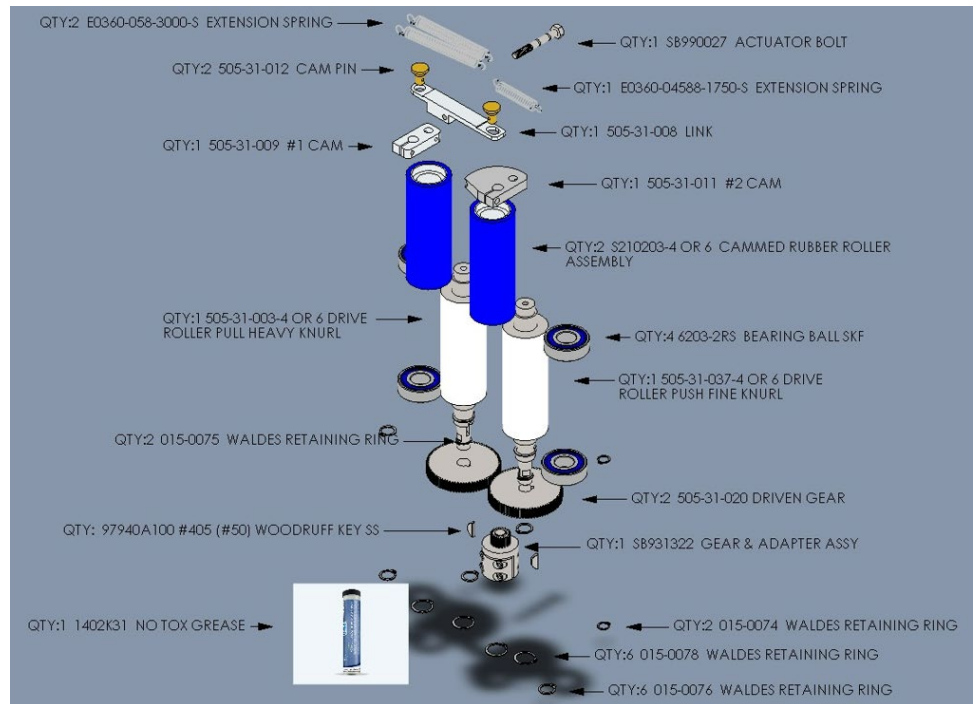

*** This kit is available for 4" and 6" Label Heads ***

Part Numbers

4" Label Head WLS Part #: KIT104

6" Label Head WLS Part #: KIT105



WLS

Rotary Labeler (Rotary Base 827/828/829)

Rotary Adapter Bearing Replacement Assembly

For more information on any product or service you find in this catalog, please feel free to contact us:

[WLS Service Mailbox](mailto:WLS@weilrls.com)

856-273-3377

<https://www.weilrls.com>

Description

Are you experiencing air leak or rotation issues on your rotary labeling systems?

This kit provides all the required parts to replace potential wear parts in one planned operation. Save money by purchasing the kit instead of individual parts.

Installation can be provided through our service department.

Parts supplied in the kit are identified in the schematic below:



Part Number

WLS Part #: KIT106



UPGRADES & RETROFITS

The robust and high-quality equipment that WLS has become known to produce results in longevity and productivity that is unmatched in the industry.

As our machines age, various electrical components with a lifespan less than our equipment will need to be replaced. Due to technical advances in many areas, some technology and components that were installed on our equipment years ago are currently in “end-of-life-cycle” phase or are already obsolete. To serve our customers at the highest level, WLS proactively researches, designs and tests retrofit kits for equipment that may be affected. As a result, we can offer solutions for affected equipment that has been designed and tested and perform an upgrade with maximum efficiency to ensure minimal downtime on your equipment, resulting in equipment that is up-to-date and ready to run for years to come.

Safety standards are a continuously evolving area in machine production and operation. While WLS has always sought to design and build both safe and compliant equipment, standards have new requirements that did not exist years ago. As a result of internal due diligence and external requests, we offer combined mechanical and integral electrical safety upgrades that meet current standards required by regulators and our customers alike.

If you would like to arrange an obsolescence review of the components on your equipment or inquire about available upgrades, please contact our WLS Service team for a quote.

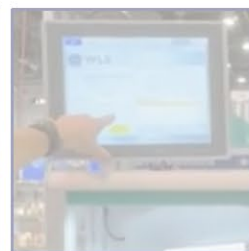



WLS® Performance Level D ISO 13849-1 Compliant Retro Guarding Package

For more information on any product or service you find in this catalog, please feel free to contact us:

[WLS Service Mailbox](#)

856-273-3377

<https://www.weilerls.com>

Description

- Includes updates to the safety circuit for the entire machine
- Eliminates safety concerns by ensuring compliance with the latest safety standards
- Clear visibility of operational components and line clearance
- Easy access to the machine
- Easy access for maintenance
- Minimal downtime – on-site installation
- Schematics below illustrate an example old and new style guarding

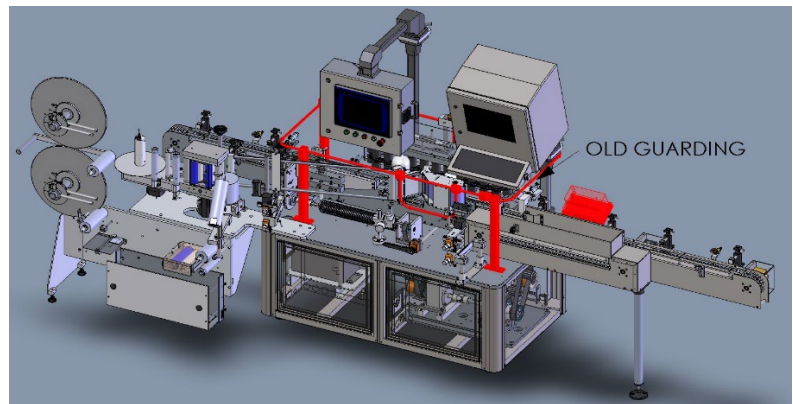

Old style “Capacitive Sensing” guard

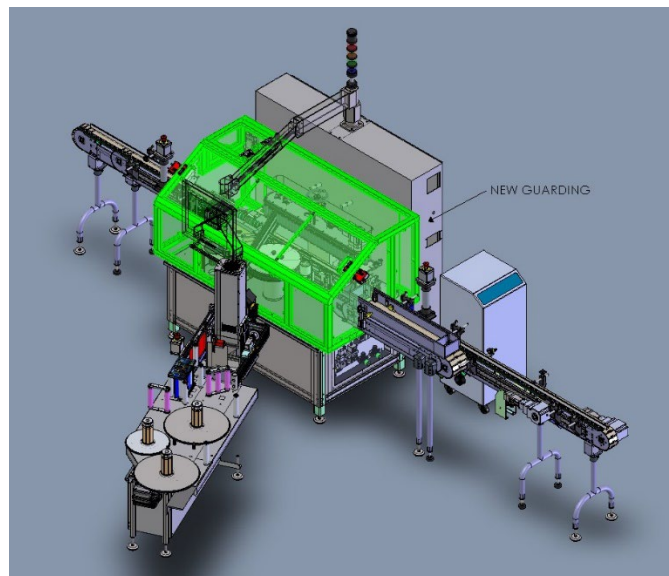

Compliant fully enclosed guarding

For more information on any product or service you find in this catalog, please feel free to contact us:

[WLS Service Mailbox](#)

856-273-3377

<https://www.weilerls.com>

Description

- Gain higher performance, increased productivity, enhanced security and scalability by converting from SLC to CompactLogix
- This conversion kit:
 - Simplifies design and engineering time
 - Decreases cost significantly
 - Reduces wiring time and wiring errors
 - Decreases installation time significantly
- Many SLC components are now discontinued and unavailable to purchase

The image shows a brochure titled "Migration solutions" for converting SLC™ 500 to CompactLogix™ 5380 control systems. It features the Allen-Bradley logo and a diagram showing the transition from SLC™ 500 controllers and SLC™ I/O to CompactLogix™ 5380 controllers and Compact 5000™ I/O systems. A "Product lifecycle" section includes a timeline with stages: ACTIVE, ACTIVE/MATURE, END OF LIFE, and DISCONTINUED. The DISCONTINUED stage is highlighted in red, indicating that SLC 500 components are no longer supported. The Rockwell Automation logo is also present.

Click image to view informational brochure

- More information, including videos about this conversion, can be found at this address: [WLS SLC to Compact Logix Conversion Info](#)

For more information on any product or service you find in this catalog, please feel free to contact us:

[WLS Service Mailbox](#)

856-273-3377

<https://www.weilerls.com>

Description

- Get ahead of the game and avoid a down equipment event without a replacement part.
- WLS can do an evaluation of your equipment to understand which items are obsolete.
- Update your equipment to the latest technology offered by WLS, to eliminate downtime due to obsolescence with no direct replacements available
- Major components such as PLC, HMI, servo drives, Variable Frequency Drives, vision systems and printing are of the most importance
- Use the contact information to the left to schedule an evaluation

