



# NJM BRONCO<sup>®</sup> 4

Versatile Pressure Sensitive Labeler

PH

PHARMA

> **Flexible** for every format.  
 Smart, **simplest** operation.  
**Future-proof** and reliable.

Designed *with* you, not for you.

The BRONCO<sup>®</sup> 4 pressure sensitive labeler is a highly versatile system designed for a wide range of container shapes. Built with a modular architecture, it applies wrap-around, front & back or multi-panel labels and achieves speeds of up to 250 units per minute.

The BRONCO<sup>®</sup> 4 is designed with the operator in mind. Its label dispenser features an easy-to-use label unwind and waste web area. Changeovers are fast and tool-less, while the operator-centric Optix™ HMI offers simple role-based screens, visual fault cues and instant status visibility.

Its robust label dispenser platform allows integration of printers. The system's PLC controls manages all machine functions including fail-safe tracking of products to facilitate vision inspection integration.

## CUSTOMER-CENTRIC DESIGN

- **Keep Lines Running.** Every detail of the consumables area built around the operator.
- **Speed. Flexibility.** The most flexible platform in the industry for speeds up to 250 BPM.
- **Next-Gen Controls.** Allen Bradley Controls with available vision inspection on a single HMI.
- **Smart & Compliant.** Role based Optix HMI with 21 CFR Part 11 and serialization ready



# BRONCO® 4 PRESSURE SENSITIVE LABELER

## TYPICAL SPECIFICATIONS

<b>Container Shapes</b>	Round, square, rectangular, oblong and oval
<b>Container Diameter</b>	Min. 0.63" (16mm), Max. 4.75" (120mm)
<b>Container Height</b>	Min. 1" (25.4mm), Max. 8" (203mm)
<b>Label Height</b>	Min. 0.5" (12.7mm), Max. 5.125" (130mm)
<b>Label Length</b>	Min. 0.625" (16mm), Max. 12" (304.8mm)

<b>Speeds</b>	Up to 250 units per minute (depending on application)
<b>Power Supply</b>	208-240 VAC, 3 phase, 50-60 Hz, 15A
<b>Air Requirement</b>	80 PSI, 2 SCFM (5.5 bar, 57 L/min)

## LABELING APPLICATIONS:



## WRAP AROUND (LEFT HAND) CONFIGURATION:

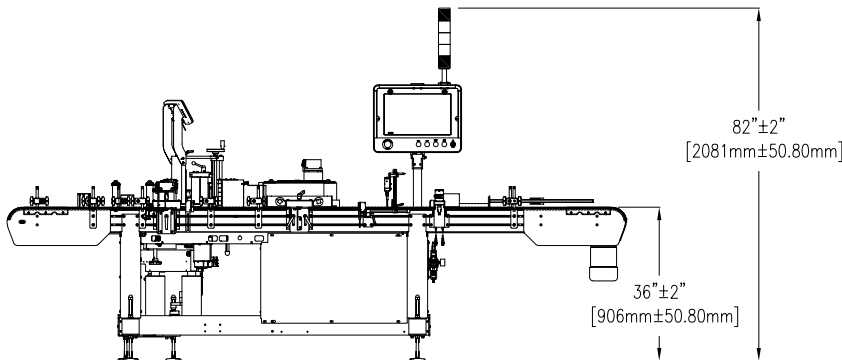
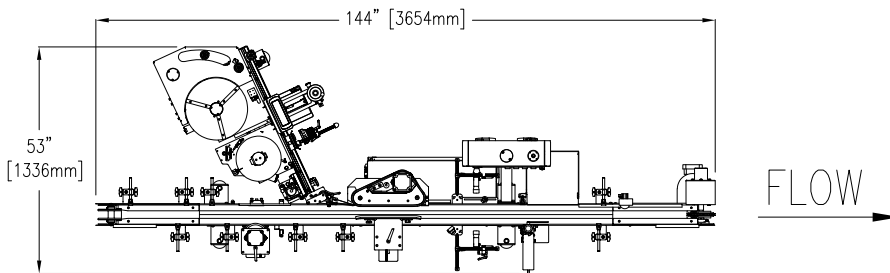

## OPTIONS

- Single or Dual Label Dispensers
- Wrap-around, multi-panel or front & back labeling
- End-of-roll staging platform
- Serialization ready
- Printers
- Vision inspection and tracking

